

48
S0.1 STRUCTURAL - FOUNDATION
1/4" = 1'-0"

SHEARWALL HOLDDOWN AT FOUNDATION						
TYPE MARK	TYPE	HARDWARE	END POST	ATTACHMENT TO END POST	ANCHORAGE TO FOUNDATION	CAPACITY
HD2	POST-INSTALLED HOLDDOWN	SIMPSON HTS	(2)-2X	(26) 0.148 X 3 NAILS	5/8" DIA. GR.36 ALL-THREAD WITH 8" EMBEDMENT WITH NUT AND WASHER	SEE SHEET S4.3 FOR DETAILS 4670
HD3	POST-INSTALLED HOLDDOWN	SIMPSON HDU8-SDS2.5	(3)-2X	(20) 1/4" X 2 1/2" SDS SCREWS	7/8" DIA. GR.36 ALL-THREAD WITH 17 1/2" EMBEDMENT WITH NUT AND WASHER	SEE SHEET S4.3 FOR DETAILS 6200
HD4	CAST IN PLACE	SIMPSON HDU14-SDS2.5	6X6	(36) 1/4" X 2 1/2" SDS SCREWS	1" DIA. GR.36 ANCHOR ROD WITH 18" EMBEDMENT	SEE SHEET S4.3 FOR DETAILS 10000

- STRUCTURAL CONNECTION NOTES:**
- MINIMUM EDGE DISTANCE TO CENTERLINE OF BOLT IS 3". AT CORNERS, THE OPPOSING EDGE DISTANCE MUST BE ≥ 6".
 - MINIMUM #4X3" LONG REINFORCING BAR LOCATED 3"-5" BELOW THE TOP OF THE SLAB IS REQUIRED TO BE CENTERED ON THE HOLDDOWN. AT CORNER, BEND THE BAR 90° AT THE CENTER
 - REFERENCE MECHANICALLY LAMINATED BUILT-UP COLUMN FOR NAILING REQUIREMENTS FOR END POST.
 - SIMPSON ATR(REQUIRED Ø) WITH SIMPSON SET-3G IS AN ACCEPTABLE OPTION.

FOOTING SCHEDULE						
TYPE MARK	NAME	COUNT	WIDTH	LENGTH	DEPTH	TYPE COMMENTS
FT1	CONCRETE STEEL COLUMN FOOTING - 4' X 4' X 2'-4"	9	4'-0"	4'-0"	2'-4"	SEE DETAIL 2B/S3.1 SEE DETAIL 2B/S3.1
FT2	CONCRETE STEEL COLUMN FOOTING 5.5' X 5.5' X 2.5'	7	5'-6"	5'-6"	2'-6"	SEE DETAIL 2B/S3.1 SEE DETAIL 2B/S3.1

PTI PARAMETERS	
E _m - CENTER	4.8"
E _m - EDGE	2.0"
Y _m - CENTER	1.0"
Y _m - EDGE	1.25"
EFFECTIVE PLASTICITY INDEX	35
ALLOW. BEARING (PSF)	1,800 PSF
MIN. BEAM EMBEDMENT BLOW FINAL GRADE	18"
MIN PERIMETER BEAM EMBEDMENT BELOW FINAL GRADE	52"

SLAB GEOMETRY	
AREA (SF)	5711 SF
PERIMETER (FT)	394 FT
SHAPE FACTOR (PERIMETER ² /AREA)	27.5

FOUNDATION SCHEDULE							
BEAM ID	DESCRIPTION	WIDTH	DEPTH	TOP BARS	BOTTOM BARS	STIRRUPS	Type Comments
GB1	GRADE BEAM - INTERIOR - 14"	14"	30"	(3) - #6	(3) - #6	#3 @24" OC	
GB2	VERTICAL MOISTURE BARRIER	14"	30"	(3) - #6	(3) - #6	#3 @24" OC	
GB2A	GRADE BEAM - PERIMETER - 14" - W/ 8" CONCRETE WALL	8"	30"	(3) - #6	(3) - #6	#3 @24" OC	SEE 1D/S3.1 FOR MORE DETAIL
GB3	GRADE BEAM - INTERIOR - 28"	28"	30"	DOUBLE GB1	DOUBLE GB1	DOUBLE GB1	(2) GB1 STIRRUP CAGES (SIDE/SIDE - SEE DETAIL 2A/S3.0
GB4	8" CONCRETE FOUNDATION	8"	36"				SEE 6A/S3.1
GB5	TURNDOWN THICKENED SLAB	12"	12"	N/R	(2) - #4	N/R	SEE DETAIL 2C/S3.1

FOUNDATION NOTES	
FOUNDATION TYPE:	BRAB TYPE III - STIFFENED NON-STRUCTURAL SLAB-ON-GROUND
SLAB THICKNESS:	5"
SLAB REINFORCEMENT:	#4 @ 16" OC EACH WAY - REF DETAIL
DESIGN METHOD:	ACI 318
VAPOR RETARDER:	MINIMUM 15 MIL (UNLESS THICKER REQ'D BY ARCHITECT)

- NOTES:**
- BEAMS ARE TYPE B1 UNO.
 - LOCATE THE FIRST STIRRUP A MAXIMUM OF 3" FROM FACE OF SUPPORT.
 - BEAM DEPTH INDICATED IN THE SCHEDULE IS A STRUCTURAL MINIMUM THAT THE BEAM REINFORCEMENT GAUGE MAY BE BASED UPON. REFERENCE GEOTECHNICAL REPORT FOR MINIMUM GRADE BEAM EMBEDMENT BELOW ADJACENT FINAL GRADE OR FLATWORK/PAVEMENT.
 - N/R = NOT REQUIRED

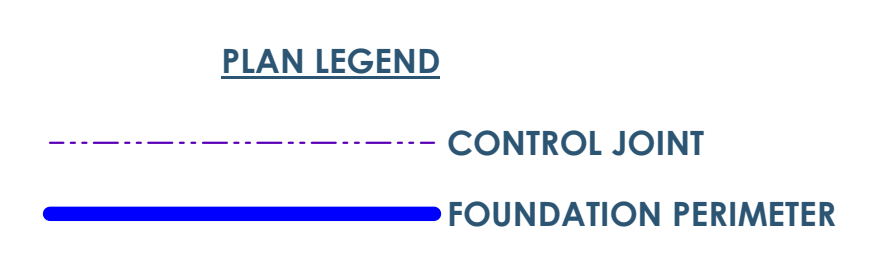

- PLAN NOTES:**
- VERIFY ALL EDGE OF FOUNDATION DIMENSIONS WITH FINAL ARCHITECTURE FLOOR PLANS.
 - FORM DIMENSIONS: SLAB DROPS, SLOPES, ETC. SHOWN AS AN AID TO CONTRACTOR ONLY. VERIFY EXACT DIMENSIONS AND LOCATIONS WITH ARCHITECT.
 - DIMENSIONS ARE TO OF GRADE BEAMS OR EDGE OF SLAB UNLESS NOTED OTHERWISE.
 - CONTROL JOINTS (SAW-CUTS) ARE RECOMMENDED TO REDUCE CRACKS IN THE SLAB, BUT ARE NOT REQUIRED FOR STRUCTURAL REQUIREMENTS. FOR THE RECOMMENDED MAXIMUM JOINT SPACING, REFERENCE DETAIL.
 - FOR FLATWORK OR PAVEMENT ABUTTING THE BUILDING FOUNDATION REFERENCE DETAIL.
 - CONCRETE IS ASSUMED TO RECEIVE A STEEL TROWEL FINISH UNLESS NOTED OTHERWISE. NOTIFY ENGINEER IF ARCHITECTUALLY EXPOSED CONCRETE (STAINED, POLISHED, ETC.) IS PLANNED FOR ADDITIONAL SHRINKAGE CRACKING MITIGATION METHODS.

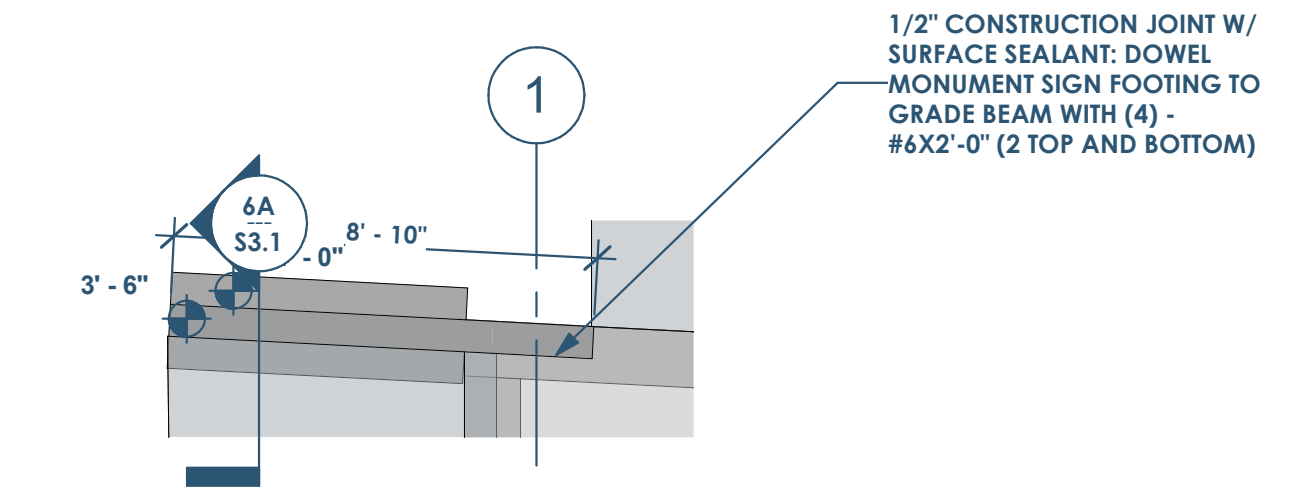

6A
S0.1 STRUCTURAL - FOUNDATION - SIGN AREA
1/4" = 1'-0"

RENOVATION Wranglers
 Owner: Renovation Wranglers
 102 E 26th St
 Bryan, TX 77803
 Katerencason@time.com | 979.450.9969

ARCHITECTURE
 Architect of Record: LKB Architecture
 2929 Allen Pkwy Suite 200
 Houston, TX 77019
 isa@lkbarchitecture.com | 713.425.3076

DUDDLEY
 Structural: Dudley
 4102 Imperial Loop Drive
 College Station, TX 77845
 (979) 777-0720

amc ENGINEERS
 MEP: AMC Engineers
 508 E Jackson St # 552
 Burnet, TX 78611
 info@amcengineers.com

This project, like most OpeningDesign's projects, is open source (Attribution-ShareAlike 4.0 International-CC BY-SA 4.0)-freely available to any party for future use, assuming the terms such as Attribution and ShareAlike are honored.

openingdesign
 Architect: OpeningDesign
 17 S Fairchild | FL 7
 Madison, WI 53703
 ryan@openingdesign.com | 773.425.6456

Date: 06/02/2022 Description: Review before Permit